















Assembly Instruction

①*1pc		A*4+1EXT	 M6*30MM+M6*14*1
②*2pcs		B*4+1EXT	 M6*25MM
③*1pc		C*10+1EXT	 M6*20MM
④*1pc		D*4+1EXT	 M6*20MM+M6*14*1
⑤*1pc		E*2+1EXT	 M6*16MM
⑥*4pcs		F*2	
⑦*1pc		G*8	
		L*1	 M6

STEP1

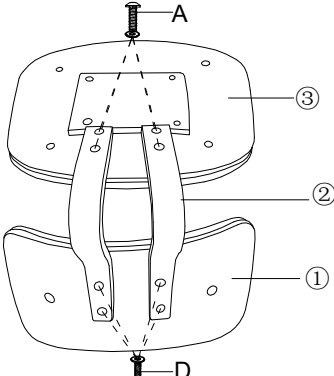

STEP2

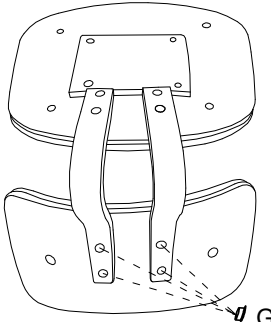

STEP3

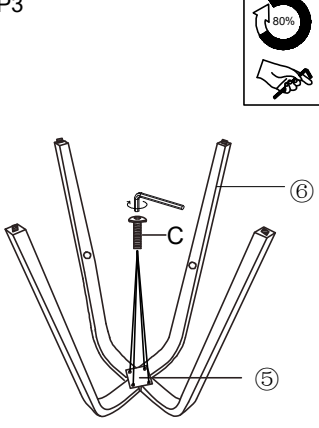

STEP4

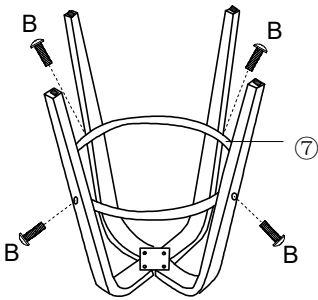

STEP5

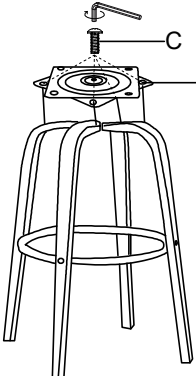

Fasten All screws indicate on Step 1& Step2.

STEP6

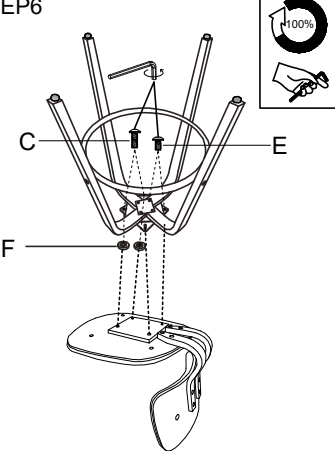

STEP7

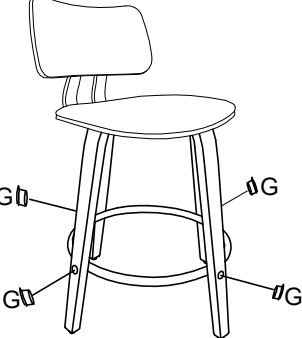

STEP8

